

LOC		DIST		P		F		ZONE		LTR		REVISIONS		DATE	APPD
AF	50													12/JAN/98	PF/JW
												E	ADD -2 PER 0L10-0469-97		

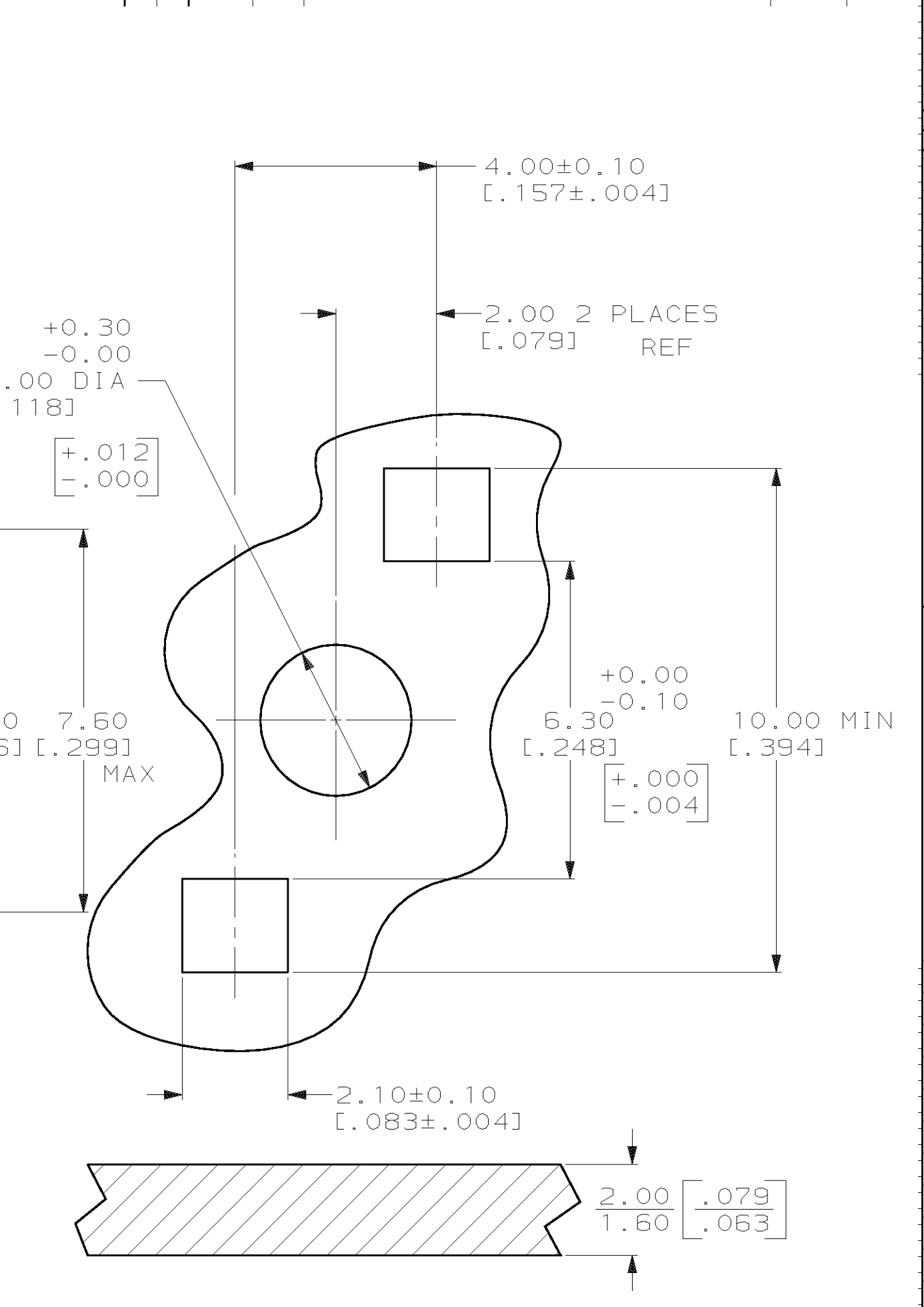
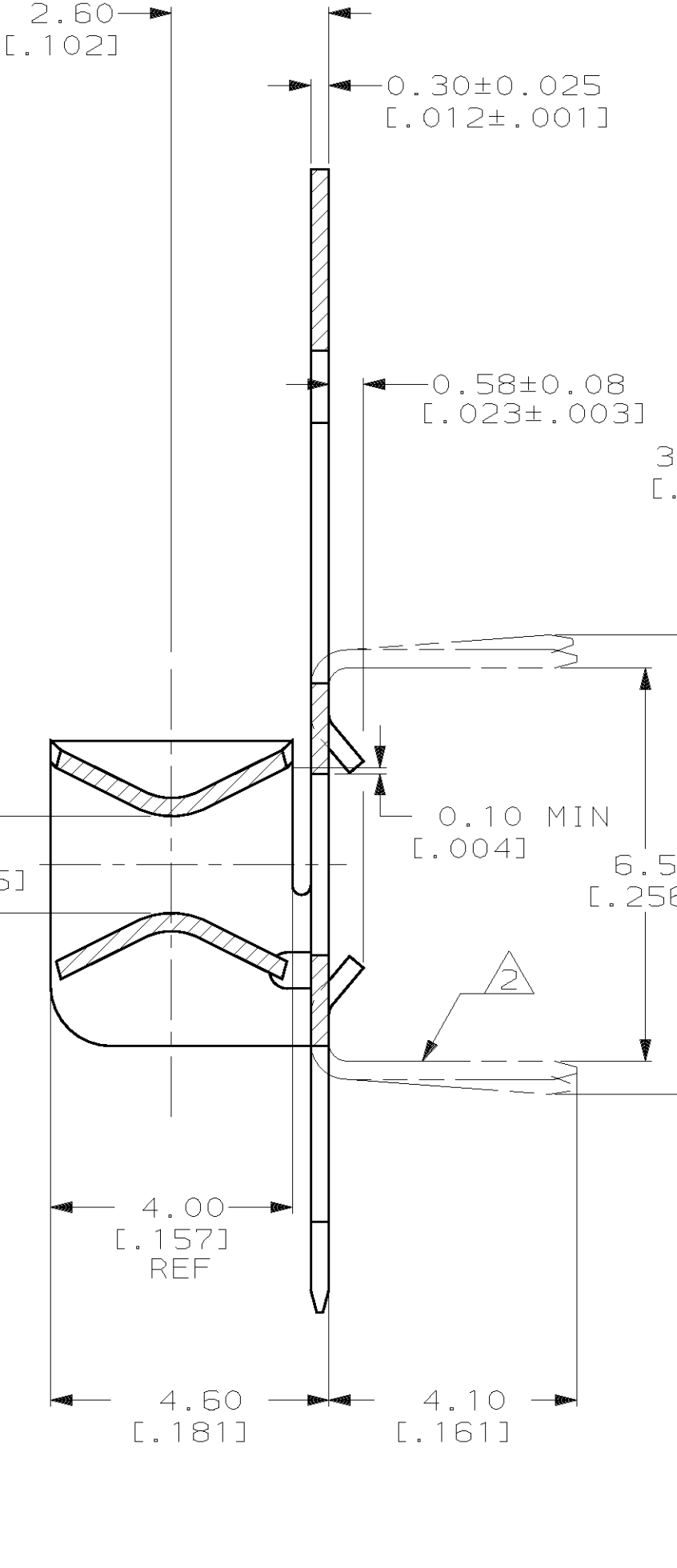
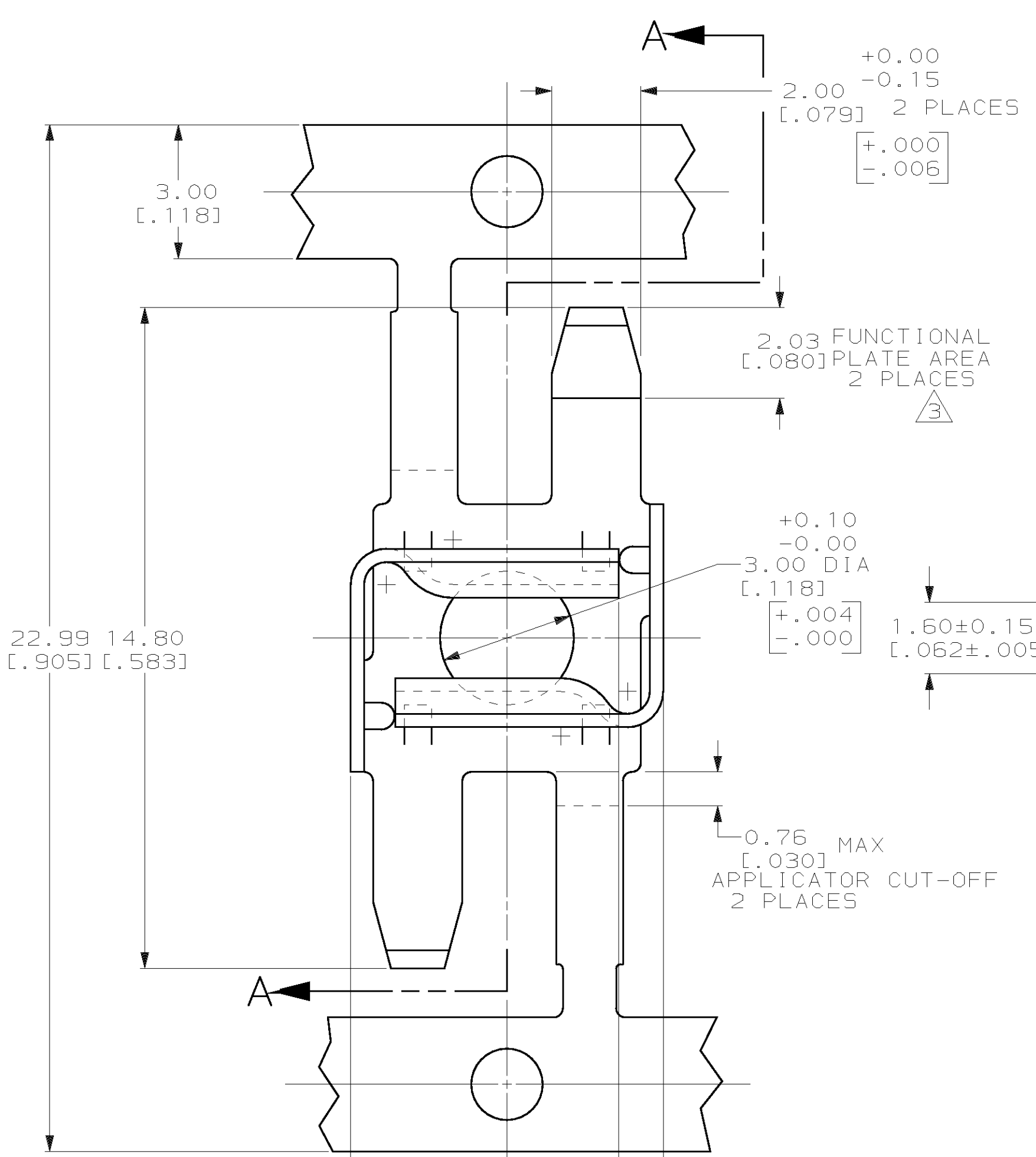

- 1 CONTINUOUS STRIP ON REELS.
- 2 TINES BENT 90° IN APPLICATOR PRIOR TO ASSEMBLY INTO P.C. BOARD.
- 3 0.00508 [.000200] MIN TIN IN FUNCTIONAL PLATE AREA, 0.00254 [.000100] MIN TIN ON REMAINDER.
- 4 PRODUCT COMPLIES WITH AMP SOLDERABILITY SPEC 109-11-5. WHEN PLATED AND 109-11-1 AFTER TWO YEARS OF SHELF LIFE

DO NOT SCALE PRINT. UNLESS SPECIFIED DIMENSIONS IN mm [INCHES] TOLERANCES ON : 2 PLC DEC \pm - 3 PLC DEC ± 0.25 [.010] ANGLES $\pm 1^\circ$	DR 2/2/90 MICHAEL S. FEHER
MATERIAL #4 HARD PHOSPHOR BRONZE	CHK 2/5/90 JR RUTH
FINISH 3	APPD 2/13/90 D. SCHWENK
	APPD 2/19/90 TERRY L. SHUTTER
	PRODUCT SPEC -
	APPLICATION SPEC -
	WEIGHT -

TRAVERSE WOUND	63566-2
NORMAL	63566-1
REELING	PART NO
AMP AMP INCORPORATED Harrisburg, Pa. 17105	
NAME PIN RECEPTACLE, PRINTED CIRCUIT BOARD, 2.25 [.088]-2.36 [.093] DIA	
SIZE C	CAGE CODE 00779
SCALE 10:1	DRAWING NO 63566
	SHEET 1 OF 1